

CONTRACT OF AGREEMENT

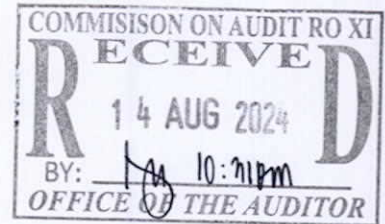

KNOW ALL MEN BY THESE PRESENTS:

This CONTRACT OF AGREEMENT made and entered into, by and between:

OFFICE OF THE OMBUDSMAN, an Agency created and established by the Constitution of the Republic of the Philippines, with office address at Sen. Meriam P. Defensor-Santiago Ave. (formerly Agham Road), Barangay Bagong Pag-asa, Diliman, Quezon City, Philippines, represented herein by **HONORABLE SAMUEL R. MARTIRES**, Ombudsman, hereinafter called "the Entity;"

-and-

RRJJ QUINTO BUILDERS CORP., with line of business as General Engineering and Building Contractor (Booking Office only) under and by virtue of the laws of the Philippines, with registered office address at Block 2, Lot 8, Maligaya Village, Catalunan Pequeño, Davao City, Philippines, represented herein by **RODEL P. QUINTO**, the duly authorized and designated representative, hereinafter called "the Supplier."

WHEREAS, the Entity, through the Bids and Awards Committee (BAC) of the Office of the Ombudsman, Area Office for Mindanao (OMB-MIN), Earth corner Libra Street, GSIS, Heights, Matina, Davao City invited Bids for certain goods and ancillary services, viz: **supply, delivery and installation of two (2) units 40-footer or four (4) units 20-footer pre-fabricated Container Van as storage facility** for OMB-MIN;

WHEREAS, the Entity, after the conduct of an open competitive bidding by the BAC of OMB-MIN, pursuant to the provisions of Republic Act No. 9184, the "Government Procurement Reform Act" and its Revised Implementing Rules and Regulations, awarded the contract to the Supplier, after finding that its proposal is the Single Calculated and Responsive Bid (SCRB) for the **supply, delivery and installation of four (4) units 20-footer pre-fabricated Container Van as storage facility** in the contract amount of **ONE MILLION THREE HUNDRED TWENTY THOUSAND SIX HUNDRED PESOS** (PhP1,320,600.00), hereinafter called "the Contract Price."

NOW THIS AGREEMENT WITNESSETH AS FOLLOWS:

1. In this Agreement, words and expressions shall have the same meanings as are respectively assigned to them in the Conditions of Contract referred to below.
2. The following documents shall be deemed to form and be read and construed as integral part of this Agreement, viz:
 - (a) Bid Form (*Annex "A" to "A-1"*), and the Price Schedule (*Annex "B"*) submitted by the Bidder/Supplier;
 - (b) General Conditions of Contract*¹ (*Annexes "C" to "C-1"*);
 - (c) Special Conditions of Contract* (*Annexes "D" to "D-3"*);
 - (d) Schedule of Requirements* (*Annex "E" to "E-1"*);
 - (e) Technical Specifications* (*Annex "F" to "F-1"*); and
 - (f) Supplemental Bid Bulletin No. 1 dated 3 May 2024 (*Annex "G"*); and
 - (g) Detailed Drawing/Plan (*Annex "H" to "H-5"*)

¹ *As stated in the Bidding documents.

3. In consideration of the payments to be made by the Entity to the Supplier as hereinafter mentioned, the Supplier hereby covenants with the Entity to provide the goods and to remedy defects therein in conformity in all respects with the provisions of the Contract and the documents referred to in No. 2 above.
4. The Entity hereby covenants to pay the Supplier in consideration of the provision of the goods and the remedying of defects therein, the Contract Price or such other sum as may become payable under the provisions of the contract at the time and in the manner prescribed by the contract.

IN WITNESS WHEREOF, the parties hereto have signed this Contract executed in accordance with the laws of the Republic of the Philippines this 29th day of May 2024.

OFFICE OF THE OMBUDSMAN
(The Entity)

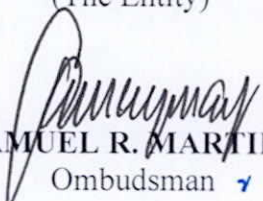

SAMUEL R. MARTIRES
Ombudsman

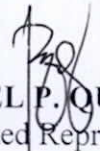
RRJJ QUINTO BUILDERS CORP.
(The Supplier)

RODEL P. QUINTO
Authorized Representative

SIGNED IN THE PRESENCE OF WITNESSES:

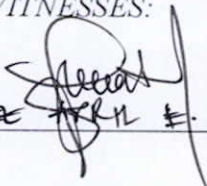
1. 

2. 

ACKNOWLEDGMENT

REPUBLIC OF THE PHILIPPINES)
QUEZON CITY) s.s.
X-----X

BEFORE ME, a Notary Public in the City of QUEZON CITY, on JUN 27 2024 2024, personally appeared OMBUDSMAN SAMUEL R. MARTIRES, with I.D. No. 180062, known to me to be the same person who executed the foregoing instrument and that he acknowledged the same to be his true and voluntary act and deed.

WITNESS MY HAND AND SEAL.

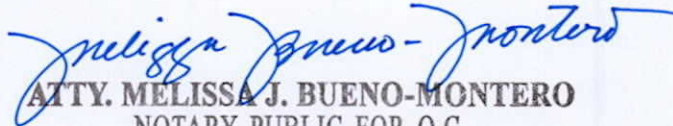
ATTY. MELISSA J. BUENO-MONTERO
NOTARY PUBLIC FOR Q.C.

NP-165 (2024-2025) UNTIL 12-31-25

PTR NO. 5453297 01-05-24 Q.C.

ROLL NO. 70230 TIN 317-955-810

IBP LIFETIME NO. 16988 05-16-17

25 BIAK NA BATO ST., BRGY. STO. NIÑO, Q.C.

MCLE COMPLIANCE NO. VII-0014550

Doc. No. 19 ;

Page No. 5 ;

Book No. II ;

Series of 2024.

-page three follows-

ACKNOWLEDGMENT

REPUBLIC OF THE PHILIPPINES)
CITY OF DAVAO) s.s.
X-----X

BEFORE ME, a Notary Public in the City of Davao, Davao del Sur on 11/13/2024 2024, personally appeared RODEL P. QUINTO, authorized representative of RRJJ QUINTO BUILDERS CORP., with I.D. No. 0111 275, known to me to be the same person who executed the foregoing instrument and that he acknowledged the same to be his true and voluntary act and deed.

WITNESS MY HAND AND SEAL.

Doc. No. 446 ;
Page No. 01 ;
Book No. VII ;
Series of 2024.

EZRA PHIL K. AZNAR
Notary Public
Com. Serial No. 215-2025
Until December 31, 2025
Roll No. 76304
PTR No. 9344561 • 12.19.2023 (2024) DC
IBP No. 329397 • 12.16.2023 (2024) DC
(MCLE Compliance is not yet required for
having been admitted to the Bar on May 4, 2022)
TIN No.: 313-321-510-00022
2/F Merco Bldg., Corner Bolton & Rizal Sts., Davao City
Office Mobile no.: 0969-501-2813

Bid Form

Date: **May 17, 2024**

Invitation to Bid¹ N^o: 2024-BOS-0001

To: *Office of the Ombudsman area office for Mindanao*

Gentlemen and/or Ladies:

Having examined the Bidding Documents including Bid Bulletin Numbers 3, the receipt of which is hereby duly acknowledged, we, the undersigned, offer to **SUPPLY, DELIVERY, AND INSTALLATION OF TWO(2) UNITS 40-FOOTER OF FOUR (4) UNITS 20 FOOTER PRE-FABRICATED CONTAINER VAN AS STORAGE FACILITY FOR THE OFFICE OF THE OMBUDSMAN, AREA OFFICE FOR MINDANAO USE** in conformity with the said Bidding Documents for the sum of **One Million Three Hundred Twenty Thousand Six Hundred Pesos (Php 1,320,600)** or such other sums as may be ascertained in accordance with the Schedule of Prices attached herewith and made part of this Bid.

We undertake, if our Bid is accepted, to deliver the goods in accordance with the delivery schedule specified in the Schedule of Requirements.

If our Bid is accepted, we undertake to provide a performance security in the form, amounts, and within the times specified in the Bidding Documents.

We agree to abide by this Bid for the Bid Validity Period specified in **BDS** provision for **ITB Clause Error! Reference source not found.** and it shall remain binding upon us and may be accepted at any time before the expiration of that period.

Commissions or gratuities, if any, paid or to be paid by us to agents relating to this Bid, and to contract execution if we are awarded the contract, are listed below:²

Name and address of agent	Amount and Currency	Purpose of Commission or gratuity
None	None	None
(if none, state "None")		

Until a formal Contract is prepared and executed, this Bid, together with your written acceptance thereof and your Notice of Award, shall be binding upon us.

¹ If ADB, JICA and WB funded projects, use IFB.

² Applicable only if the Funding Source is the ADB, JICA or WB.

RRJJ QUINTO BUILDER CORP.

ENGR. RODEL P. QUINTO
P.L. No. 0111276

ANNEX " A-1 "

We understand that you are not bound to accept the Lowest Calculated Bid or any Bid you may receive.

We certify/confirm that we comply with the eligibility requirements as per ITB Clause **Error! Reference source not found.** of the Bidding Documents.

We likewise certify/confirm that the undersigned, **Rodel P. Quinto** is granted full power and authority by the **RRJJ QUINTO BUILDER CORP.**, to participate, submit the bid, and to sign and execute the ensuing contract on the latter's behalf for **SUPPLY, DELIVERY, AND INSTALLATION OF TWO(2) UNITS 40-FOOTER OF FOUR (4) UNITS 20 FOOTER PRE-FABRICATED CONTAINER VAN AS STORAGE FACILITY FOR THE OFFICE OF THE OMBUDSMAN, AREA OFFICE FOR MINDANAO USE** of the Office of the Ombudsman Area Office for Mindanao.

We acknowledge that failure to sign each and every page of this Bid Form, including the attached Schedule of Prices, shall be a ground for the rejection of our bid.

Dated this 17th day of May, 2024.

[signature]



President
[in the capacity of]

Duly authorized to sign Bid for and on behalf of : **RRJJ QUINTO BUILDERS CORP.**

RRJJ QUINTO BUILDER CORP.
ENGR. **RODEL P. QUINTO**
PRESIDENT Lic. No. 0111275

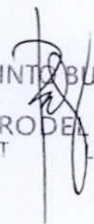

ANNEX " B "



RRJJ QUINTO BUILDERS CORP.

GENERAL ENGINEERING

Block 2 Lot 8 Maligaya Village Catalunan Pequeno, Davao City
PCAB Lic. # 48445
TIN : 753-634-623-000

GENERAL BUILDING

Email : rrjjquintobuilders@yahoo.com
Tel. No. : (082) 225-55-21
Mobile No. 09475880539

PRICE SCHEDULE FORM

Name of Bidder: RRJJ QUINTO BUILDERS CORPORATION

ITB No.: 2024-BOS-0001

Project Title: Supply, Delivery, and Installation of two(2) units 40-footer of Four (4) units 20 footer pre-fabricated container van as storage facility for the office of the ombudsman, Area office for Mindanao use.
ABC = P 1,330,560.00

1	2	3	4	5	6	7	8	9	10
ITEM	DESCRIPTION	COUNTRY OF ORIGIN	QUANTITY	Direct Cost		Indirect Cost			Total Price Delivered Final Destination (Bid Price) (col. 6+7+8+9)
				Estimated Price/ Cost per unit	cost of labor, raw materials and component	Sales and other taxes Payable	Cost of Other incidental Services	Unit Price EXW (col 4. x Col.5)	
1	Basic Detachable Prefabricated Multi Purpose House 20-footer (4 sets) with Installation		1 lot	596,000.00	5,000.00	29,800.00	5,000.00	596,000.00	635,800.00
2	Electrical, 4 sets (See Technical Specs)		1 lot	65,000.00	5,000.00	3,250.00	5,000.00	65,000.00	78,250.00
3	Sandwich Panel Rain Cover (See Technical Specs)		1 lot	46,000.00	5,000.00	2,300.00	5,000.00	46,000.00	58,300.00
4	DIY Bathroom Outside/Extension (see Technical Specs)		1 lot	125,000.00	5,000.00	6,250.00	5,000.00	125,000.00	141,250.00
5	Powder Coated Connecting Plates (3 sets) (see Technical Specs)		1 lot	100,000.00	5,000.00	5,000.00	5,000.00	100,000.00	115,000.00
6	Additional Floor Purlins use for the Flooring, Additional weight capacity and connecting 2 units (4 sets) (See Technical Specs)		1 lot	100,000.00	5,000.00	5,000.00	5,000.00	100,000.00	115,000.00
7	1.5 HP Aircon (2 Units) (See Technical Specs)		1 lot	50,000.00	5,000.00	2,500.00	5,000.00	50,000.00	62,500.00
8	Concrete Footing (Pedestal) & Stairs(4 sets) (See Technical Specs)		1 lot	50,000.00	5,000.00	2,500.00	5,000.00	50,000.00	62,500.00
9	Special/Trucking/Lab or Transportation Service & Outside Davao Allowance		1 lot	40,000.00	5,000.00	2,000.00	5,000.00	40,000.00	52,000.00
TOTAL BID PRICE (P) =									1,320,600.00
TOTAL PRICE IN WORDS : One Million Three Hundred Twenty Thousand Six Hundred Pesos Only									

Engr. Rodell P. Quinto

Name and Signature of Authorized Representative

May 17, 2024

Date

RRJJ QUINTO BUILDERS CORP.
ENGR. RODELL P. QUINTO
Lic. No. 0111276

Section IV. General Conditions of Contract

Notes on the General Conditions of Contract

The General Conditions of Contract (GCC) in this Section, read in conjunction with the Special Conditions of Contract in Section V and other documents listed therein, should be a complete document expressing all the rights and obligations of the parties.

Matters governing performance of the Supplier, payments under the contract, or matters affecting the risks, rights, and obligations of the parties under the contract are included in the GCC and Special Conditions of Contract.

Any complementary information, which may be needed, shall be introduced only through the Special Conditions of Contract.

1. Scope of Contract

This Contract shall include all such items, although not specifically mentioned, that can be reasonably inferred as being required for its completion as if such items were expressly mentioned herein. All the provisions of RA No. 9184 and its 2016 revised IRR, including the Generic Procurement Manual, and associated issuances, constitute the primary source for the terms and conditions of the Contract, and thus, applicable in contract implementation. Herein clauses shall serve as the secondary source for the terms and conditions of the Contract.

This is without prejudice to Sections 74.1 and 74.2 of the 2016 revised IRR of RA No. 9184 allowing the GPPB to amend the IRR, which shall be applied to all procurement activities, the advertisement, posting, or invitation of which were issued after the effectivity of the said amendment.

Additional requirements for the completion of this Contract shall be provided in the **Special Conditions of Contract (SCC)**.

2. Advance Payment and Terms of Payment

- 2.1. Advance payment of the contract amount is provided under Annex "D" of the revised 2016 IRR of RA No. 9184.
- 2.2. The Procuring Entity is allowed to determine the terms of payment on the partial or staggered delivery of the Goods procured, provided such partial payment shall correspond to the value of the goods delivered and accepted in accordance with prevailing accounting and auditing rules and regulations. The terms of payment are indicated in the SCC.

3. Performance Security

Within ten (10) calendar days from receipt of the Notice of Award by the Bidder from the Procuring Entity but in no case later than prior to the signing of the Contract by both parties, the successful Bidder shall furnish the performance security in any of the forms prescribed in Section 39 of the 2016 revised IRR of RA No. 9184.

4. Inspection and Tests

The Procuring Entity or its representative shall have the right to inspect and/or to test the Goods to confirm their conformity to the Project specifications at no extra cost to the Procuring Entity in accordance with the Generic Procurement Manual.

All reasonable facilities and assistance for the inspection and testing of Goods, including access to drawings and production data, shall be provided by the Supplier to the authorized inspectors at no charge to the Procuring Entity.

5. Warranty

5.1. In order to assure that manufacturing defects shall be corrected by the Supplier, a warranty shall be required from the Supplier as provided under Section 62.1 of the 2016 revised IRR of RA No. 9184.

5.2. The Procuring Entity shall promptly notify the Supplier in writing of any claims arising under this warranty. Upon receipt of such notice, the Supplier shall, repair or replace the defective Goods or parts thereof without cost to the Procuring Entity, pursuant to the Generic Procurement Manual.

6. Liability of the Supplier

The Supplier's liability under this Contract shall be as provided by the laws of the Republic of the Philippines.

If the Supplier is a joint venture, all partners to the joint venture shall be jointly and severally liable to the Procuring Entity.

Special Conditions of Contract

GCC Clause	
1	<p>Must have the requirements enumerated below:</p> <p>Delivery and Documents –</p> <p>For purposes of the Contract, “EXW,” “FOB,” “FCA,” “CIF,” “CIP,” “DDP” and other trade terms used to describe the obligations of the parties shall have the meanings assigned to them by the current edition of INCOTERMS published by the International Chamber of Commerce, Paris. The Delivery terms of this Contract shall be as follows:</p> <p><i>[For Goods supplied from abroad, state:]</i> “The delivery terms applicable to the Contract are DDP delivered <i>[indicate place of destination]</i>. In accordance with INCOTERMS.”</p> <p><i>[For Goods supplied from within the Philippines, state:]</i> “The delivery terms applicable to this Contract are delivered <i>[indicate place of destination]</i>. Risk and title will pass from the Supplier to the Procuring Entity upon receipt and final acceptance of the Goods at their final destination.”</p> <p>Delivery of the Goods shall be made by the Supplier in accordance with the terms specified in Section VI (Schedule of Requirements).</p> <p>For purposes of this Clause the Procuring Entity’s Representative at the Project Site are:</p> <ol style="list-style-type: none"> 1.) GIPO III Nelson D. Edralin - TWG, Chairperson 2.) AGIO III Arizona Martin J. Boiser - Head, BAC Secretariat; and 3.) Other duly authorized representative of the Office. <p>Incidental Services –</p> <p>The Supplier is required to provide all of the following services, including additional services, if any, specified in Section VI. Schedule of Requirements: <i>Select appropriate requirements and delete the rest.</i></p> <ol style="list-style-type: none"> a. performance or supervision of on-site assembly and/or start-up of the supplied Goods; b. furnishing of tools required for assembly and/or maintenance of the supplied Goods; c. furnishing of a detailed operations and maintenance manual for each appropriate unit of the supplied Goods; d. performance or supervision or maintenance and/or repair of the supplied Goods, for a period of time agreed by the parties, provided that this service shall not relieve the Supplier of any warranty obligations under this Contract; and

- e. training of the Procuring Entity's personnel, at the Supplier's plant and/or on-site, in assembly, start-up, operation, maintenance, and/or repair of the supplied Goods.
- f. *[Specify additional incidental service requirements, as needed.]*

The Contract price for the Goods shall include the prices charged by the Supplier for incidental services and shall not exceed the prevailing rates charged to other parties by the Supplier for similar services.

Spare Parts –

The Supplier is required to provide all of the following materials, notifications, and information pertaining to spare parts manufactured or distributed by the Supplier:

Select appropriate requirements and delete the rest.

- a. such spare parts as the Procuring Entity may elect to purchase from the Supplier, provided that this election shall not relieve the Supplier of any warranty obligations under this Contract.

The spare parts and other components required are listed in **Section VI (Schedule of Requirements)** and the cost thereof are included in the contract price.

The Supplier shall carry sufficient inventories to assure ex-stock supply of consumable spare parts or components for the Goods for a period of *(number of months or year)*.

Spare parts or components shall be supplied as promptly as possible, but in any case, within *(number of months or years)* of placing the order.

Packaging –

The Supplier shall provide such packaging of the Goods as is required to prevent their damage or deterioration during transit to their final destination, as indicated in this Contract. The packaging shall be sufficient to withstand, without limitation, rough handling during transit and exposure to extreme temperatures, salt and precipitation during transit, and open storage. Packaging case size and weights shall take into consideration, where appropriate, the remoteness of the Goods' final destination and the absence of heavy handling facilities at all points in transit.

The packaging, marking, and documentation within and outside the packages shall comply strictly with such special requirements as shall be expressly provided for in the Contract, including additional requirements, if any, specified below, and in any subsequent instructions ordered by the Procuring Entity.

	<p>The outer packaging must be clearly marked on at least four (4) sides as follows:</p> <p>Name of the Procuring Entity Name of the Supplier Contract Description Final Destination Gross weight Any special lifting instructions Any special handling instructions Any relevant HAZCHEM classifications</p>
	<p>A packaging list identifying the contents and quantities of the package is to be placed on an accessible point of the outer packaging if practical. If not practical the packaging list is to be placed inside the outer packaging but outside the secondary packaging.</p> <p>Transportation –</p> <p>Where the Supplier is required under Contract to deliver the Goods CIF, CIP, or DDP, transport of the Goods to the port of destination or such other named place of destination in the Philippines, as shall be specified in this Contract, shall be arranged and paid for by the Supplier, and the cost thereof shall be included in the Contract Price.</p> <p>Where the Supplier is required under this Contract to transport the Goods to a specified place of destination within the Philippines, defined as the Project Site, transport to such place of destination in the Philippines, including insurance and storage, as shall be specified in this Contract, shall be arranged by the Supplier, and related costs shall be included in the contract price.</p>
	<p>Where the Supplier is required under Contract to deliver the Goods CIF, CIP or DDP, Goods are to be transported on carriers of Philippine registry. In the event that no carrier of Philippine registry is available, Goods may be shipped by a carrier which is not of Philippine registry provided that the Supplier obtains and presents to the Procuring Entity certification to this effect from the nearest Philippine consulate to the port of dispatch. In the event that carriers of Philippine registry are available but their schedule delays the Supplier in its performance of this Contract the period from when the Goods were first ready for shipment and the actual date of shipment the period of delay will be considered force majeure.</p> <p>The Procuring Entity accepts no liability for the damage of Goods during transit other than those prescribed by INCOTERMS for DDP deliveries. In the case of Goods supplied from within the Philippines or supplied by domestic Suppliers risk and title will not be deemed to have passed to the Procuring Entity until their receipt and final acceptance at the final destination.</p>

	<p>Intellectual Property Rights –</p> <p>The Supplier shall indemnify the Procuring Entity against all third-party claims of infringement of patent, trademark, or industrial design rights arising from use of the Goods or any part thereof.</p>
4	The inspections and tests that will be conducted are:

Section VI. Schedule of Requirements

The delivery schedule expressed as weeks/months stipulates hereafter a delivery date which is the date of delivery to the project site.

Item Number	Description	Quantity	Total	Delivered, Days/ Weeks/Months
1.)	Supply, delivery and installation of two (2) units 40-footer or four (4) units 20-footer pre-fabricated Container Van as storage facility with the following details:	1 lot	1 lot	90 calendar days from receipt of PO/Contract
	Basic Detachable Prefabricated Multi-purpose House 20-footer, (4 sets)			Unit Size: 3m*5.95m*(h)2.8m Wall: 50mm EPS Steel Sandwich Panel Main Frame: -2.4mm Bended Galvanized Steel Powder Coated -2pcs. UPVC single glass security window -Steel Frame Door - MgO Fiber Cement Floor Board
	Electricals, (4 sets)			Panel Board 3-4 branches 2P with breakers THHN wires # 14 # 12 # 10 2 pcs. Surface Type Led Panel Light 18w white 1pc. 1 gang switch 1pc. 2 gang-outlet 1pc. AC outlet Flexible Electrical Pipe Consumables Labor
	Sandwich Panel Rain Cover			3 set
	DIY Bathroom Outside/Extension (1 set)			Size: 1.5m*1.4m Division and PVC door with louver 3 pcs. 2555 Sandwich Panel Roof 3L-U Shape Steel 3L 2x4x1.5 sq. tube 2 pcs. MGO Floor Water-closet and Fittings with bidet Lavatory and fittings Shower and faucet PPR Pipes and Fittings Drain 3" 4" PVC Pipes and fittings series 1000 Tiles and PVC Tile Trims Tile Adhesive Electricals (1 led light, 1 switch, 1 3prong outlet, exhaust fan)

Powder Coated Connecting Plates (3 set)	Additional Ceiling 2 pcs. Powder Coated, Short Column Bended Steel Plates 1 pc. MgO Fiber Cement Board for Floor Consumables
Additional Floor Purlins use for the flooring, additional weight capacity and connecting 2 units (4 sets)	5 L. Galvanized 50mm*50mm Square Tube 1.5mm Thickness Consumables Cutting and Welding
1.5 HP Aircon (2 units)	1.5 HP Aircon Window Inverter Type Installation Brackets
Concrete Footing (Pedestal) & Stairs (4 sets)	.40m x .40m Footing (6 pcs./set) 300mm Height Stairs Labor Consumables
Special/Trucking/Labor Transportation Service & Outside Davao Allowance	Davao City
Installation	

Section VII. Technical Specifications

Notes for Preparing the Technical Specifications

A set of precise and clear specifications is a prerequisite for Bidders to respond realistically and competitively to the requirements of the Procuring Entity without qualifying their Bids. In the context of Competitive Bidding, the specifications (*e.g.* production/delivery schedule, manpower requirements, and after-sales service/parts, descriptions of the lots or items) must be prepared to permit the widest possible competition and, at the same time, present a clear statement of the required standards of workmanship, materials, and performance of the goods and services to be procured. Only if this is done will the objectives of transparency, equity, efficiency, fairness, and economy in procurement be realized, responsiveness of bids be ensured, and the subsequent task of bid evaluation and post-qualification facilitated. The specifications should require that all items, materials and accessories to be included or incorporated in the goods be new, unused, and of the most recent or current models, and that they include or incorporate all recent improvements in design and materials unless otherwise provided in the Contract.

Samples of specifications from previous similar procurement are useful in this respect. The use of metric units is encouraged. Depending on the complexity of the goods and the repetitiveness of the type of procurement, it may be advantageous to standardize the General Technical Specifications and incorporate them in a separate subsection. The General Technical Specifications should cover all classes of workmanship, materials, and equipment commonly involved in manufacturing similar goods. Deletions or addenda should then adapt the General Technical Specifications to the particular procurement.

Care must be taken in drafting specifications to ensure that they are not restrictive. In the specification of standards for equipment, materials, and workmanship, recognized Philippine and international standards should be used as much as possible. Where other particular standards are used, whether national standards or other standards, the specifications should

Technical Specifications

TECHNICAL SPECIFICATIONS				
Item / Service	Maximum Quantity	Technical Specifications / Scope of Work	Statement of Compliance	
Supply, delivery and installation of two (2) units 40-footer or four (4) units 20-footer pre-fabricated Container Van as storage facility	1 lot	Basic Detachable Prefabricated Multi-purpose House 20-footer, (4 sets)	[Bidders must state here either "Comply" or "Not Comply" against each of the individual parameters of each Specification stating the corresponding performance parameter of the equipment offered. Statements of "Comply" or "Not Comply" must be supported by evidence in a Bidders Bid and cross-referenced to that evidence. Evidence shall be in the form of manufacturer's un-amended sales literature, unconditional statements of specification and compliance issued by the manufacturer, samples, independent test data etc., as appropriate. A statement that is not supported by evidence or is subsequently found to be contradicted by the evidence presented will render the Bid under evaluation liable for rejection. A statement either in the Bidder's statement of compliance or the supporting evidence that is found to be false either during Bid evaluation, post-qualification or the execution of the Contract may be regarded as fraudulent and render the Bidder or supplier liable for prosecution.]	
		security window Steel Frame Door MgO Fiber Cement Floor Board		
		Electricals, (4 sets)		-Panel Board 3-4 branches 2P with breakers -THHN wires # 14 # 12 # 10 -2 pcs. Surface Type Led Panel Light 18w white -1pc. 1 gang switch -1pc. 2 gang-outlet -1pc. AC outlet -Flexible Electrical Pipe -Consumables -Labor
		Sandwich Panel Rain Cover		-3 set
		DIY Bathroom Outside/Extension (1 set)		-Size: 1.5m*1.4m -Division and PVC door with louver -3 pcs. 2555 Sandwich Panel Roof -3L-U Shape Steel -3L 2x4x1.5 sq. tube -2 pcs. MGO Floor -Water-closet and Fittings with bidet -Lavatory and fittings -Shower and faucet -PPR Pipes and Fittings -Drain -3" 4" PVC Pipes and fittings series 1000 -Tiles and PVC Tile Trims -Tile Adhesive -Electricals (1 led light, 1 switch, 1 3prong outlet, exhaust fan)
Powder Coated Connecting Plates (3 set)	-Additional Ceiling -2 pcs. Powder Coated, Short Column Bended Steel Plates -1 pc. MgO Fiber Cement Board for Floor -Consumables			

Additional Floor Purlins use for the flooring, additional weight capacity and connecting 2 units (4 sets)	-5 L. Galvanized 50mm*50mm Square Tube -1.5mm Thickness -Consumables -Cutting and Welding
1.5 HP Aircon (2 units)	-1.5 HP Aircon Window Inverter Type -Installation -Brackets
Concrete Footing (Pedestal) & Stairs (4 sets)	-.40m x .40m Footing (6 pcs./set) -300mm Height Stairs -Labor -Consumables
Special/Trucking/Lab or Transportation Service & Outside Davao Allowance	-Davao City
Installation	

Section VIII. Checklist of Technical and Financial Documents

Notes on the Checklist of Technical and Financial Documents

The prescribed documents in the checklist are mandatory to be submitted in the Bid, but shall be subject to the following:

- a. GPPB Resolution No. 09-2020 on the efficient procurement measures during a State of Calamity or other similar issuances that shall allow the use of alternate documents in lieu of the mandated requirements; or
- b. Any subsequent GPPB issuances adjusting the documentary requirements after the effectivity of the adoption of the PBDs.

The BAC shall be checking the submitted documents of each Bidder against this checklist to ascertain if they are all present, using a non-discretionary "pass/fail" criterion pursuant to Section 30 of the 2016 revised IRR of RA No. 9184.



Republic of the Philippines
OFFICE OF THE OMBUDSMAN
Area Office for Mindanao
Earth corner Libra Street, GSIS Heights,
Matina, Davao City

BIDS AND AWARDS COMMITTEE
Supplemental Bid Bulletin No. 1
03 May 2024

This Supplemental Bid Bulletin No. 1 is issued with an attached Detailed Drawing/Plan for the Procurement of Goods, for the supply, delivery, and installation of two (2) units 40-footer or four (4) units 20-footer pre-fabricated Container Van as Storage Facility for the Office of the Ombudsman, Area Office for Mindanao use.

For the guidance and information of all concerned.

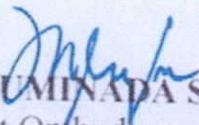
MARIA ILLUMINADA S. LAPID-VIVA
Assistant Ombudsman/Chairperson,
Bids and Awards Committee

ANNEX " H "

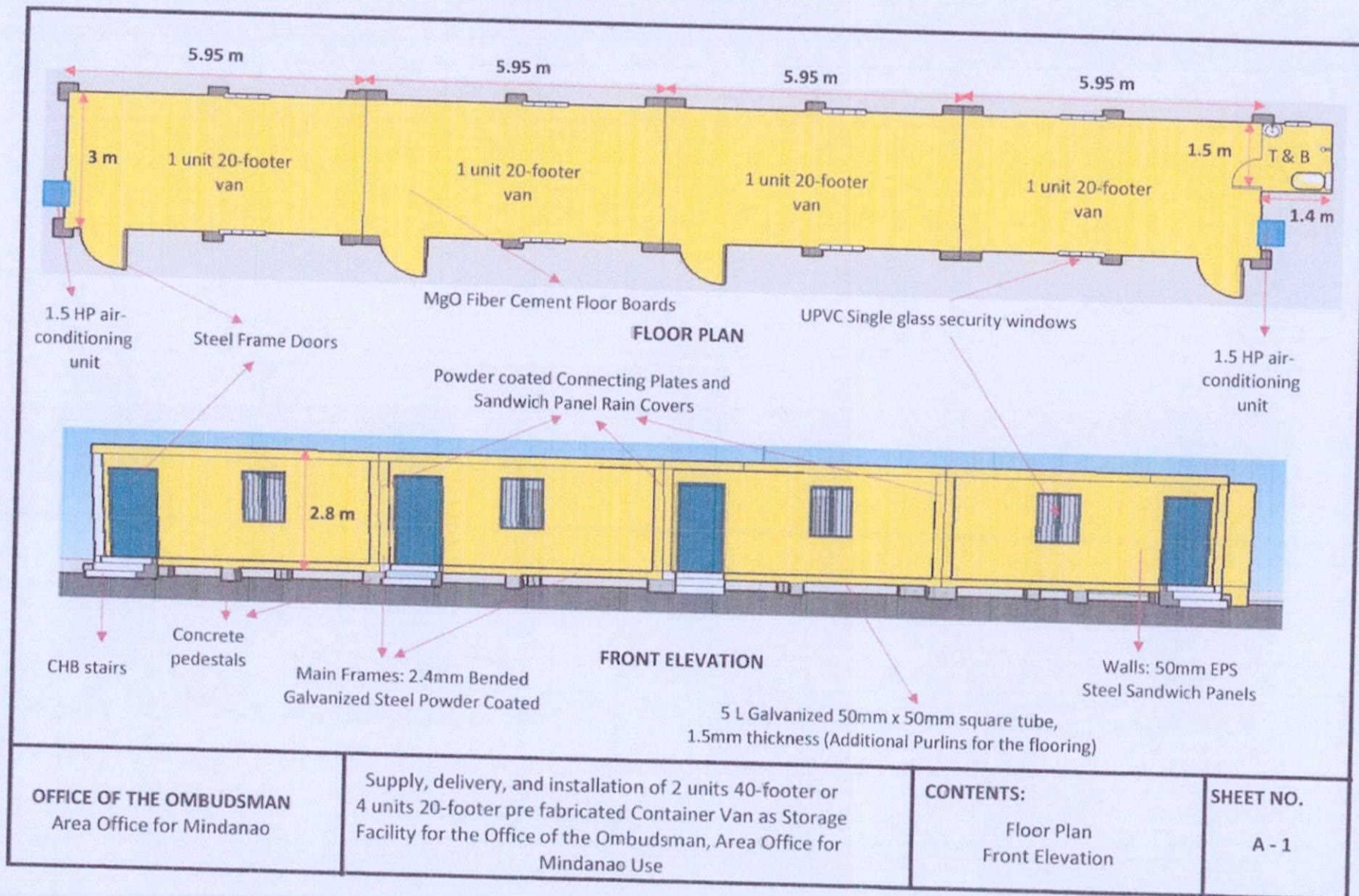

ANNEX "H-1"

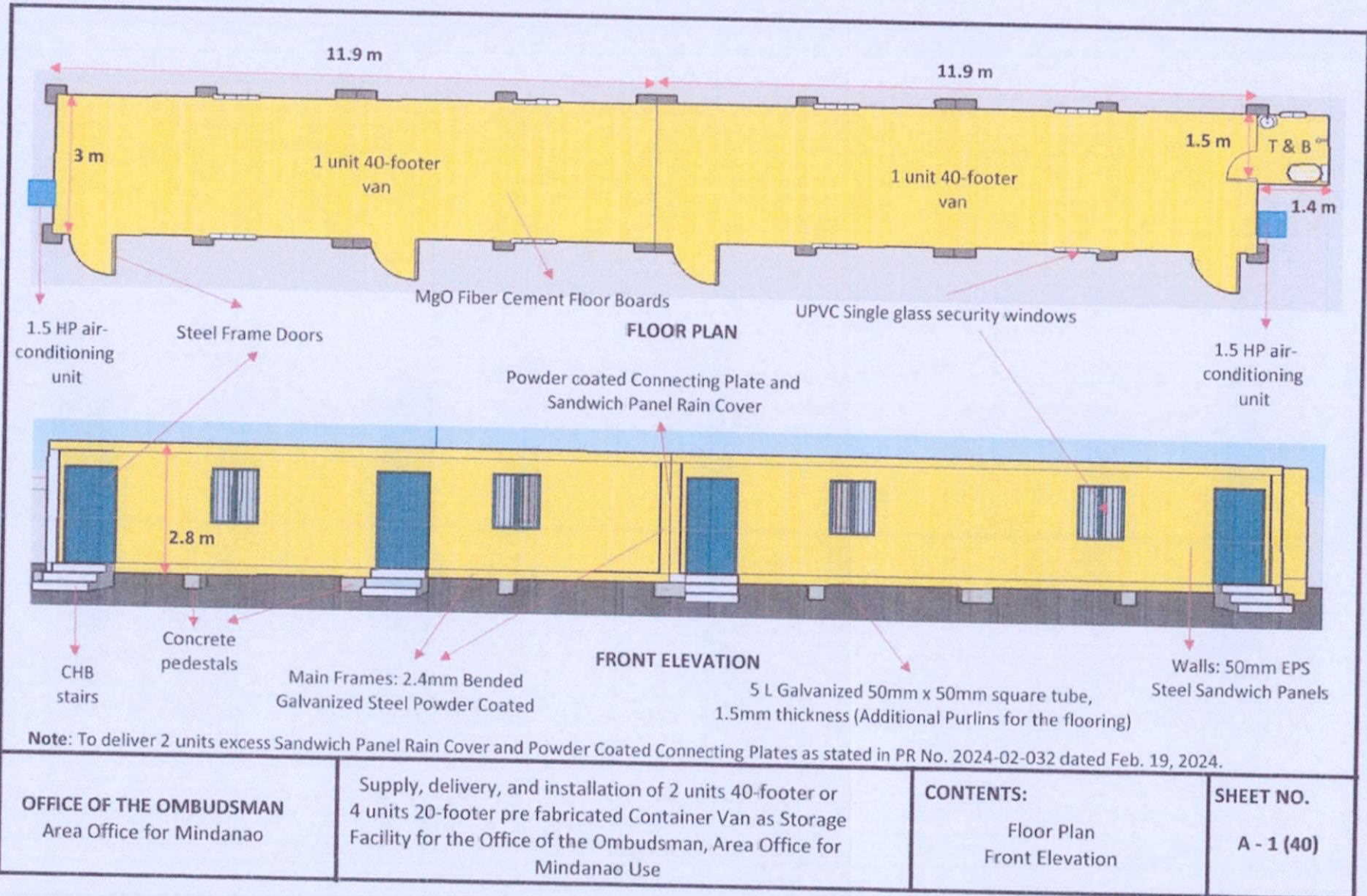

ANNEX " H-2 "

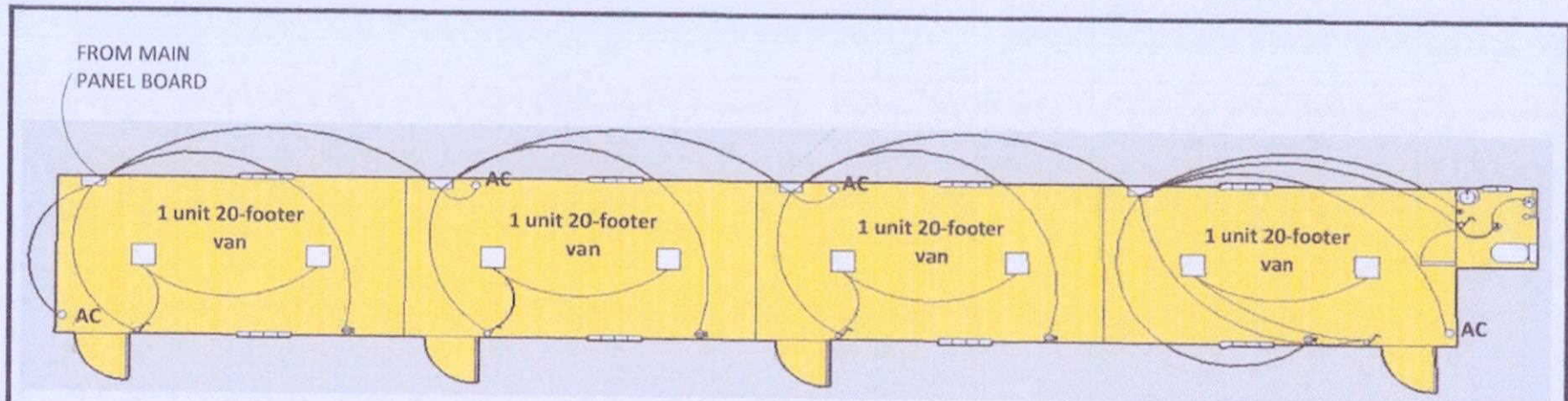

ELECTRICAL AND POWER LAYOUT

LEGEND

SYMBOL	DESCRIPTION	SYMBOL	DESCRIPTION
□	Panel Board 3-4 branches 2p with breakers		
□	Surface Type LED Panel Light 18w white	⊙	Exhaust fan
○ AC	Air-conditioning unit outlet	⊙	LED Light
⊙	1-gang switch	⊕	3-prong outlet
⊖	2-gang outlet		

- Notes:**
- For wires from panel board to panel board, use #10 THHN wire
 - For wires from panel board to AC outlet, use #12 THHN wire
 - For wires from panel board to lighting and power outlet, use #14 THHN wire

<p>OFFICE OF THE OMBUDSMAN Area Office for Mindanao</p>	<p>Supply, delivery, and installation of 2 units 40-footer or 4 units 20-footer pre fabricated Container Van as Storage Facility for the Office of the Ombudsman, Area Office for Mindanao Use</p>	<p>CONTENTS: Electrical and Power Layout</p>	<p>SHEET NO. E - 1</p>
--	--	---	-----------------------------------

ANNEX " H-3 "

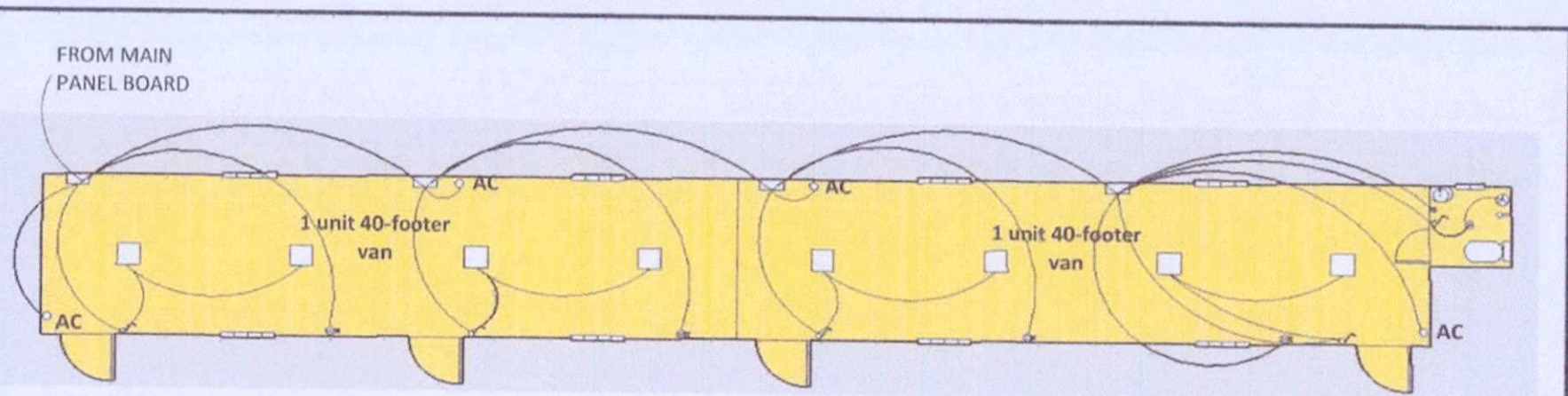

ELECTRICAL AND POWER LAYOUT

LEGEND

SYMBOL	DESCRIPTION	SYMBOL	DESCRIPTION
	Panel Board 3-4 branches 2p with breakers		Exhaust fan
	Surface Type LED Panel Light 18w white		LED Light
	Air-conditioning unit outlet		3-prong outlet
	1-gang switch		
	2-gang outlet		

Notes:

- For wires from panel board to panel board, use #10 THHN wire
- For wires from panel board to AC outlet, use #12 THHN wire
- For wires from panel board to lighting and power outlet, use #14 THHN wire

<p>OFFICE OF THE OMBUDSMAN Area Office for Mindanao</p>	<p>Supply, delivery, and installation of 2 units 40-footer or 4 units 20-footer pre fabricated Container Van as Storage Facility for the Office of the Ombudsman, Area Office for Mindanao Use</p>	<p>CONTENTS: Electrical and Power Layout</p>	<p>SHEET NO. E - 1 (40)</p>
---	--	--	---------------------------------

ANNEX "H-4"

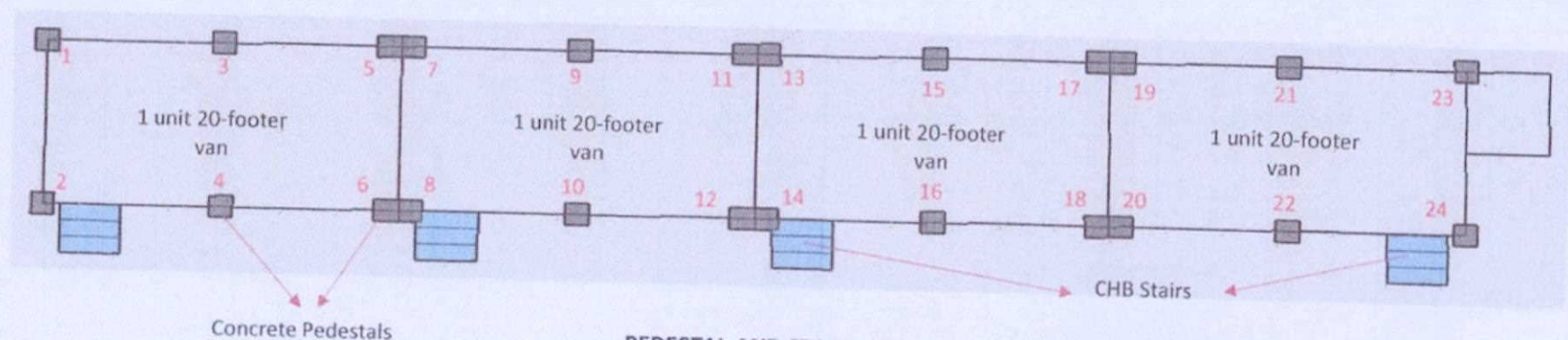

PEDESTAL AND STAIRS LAYOUT

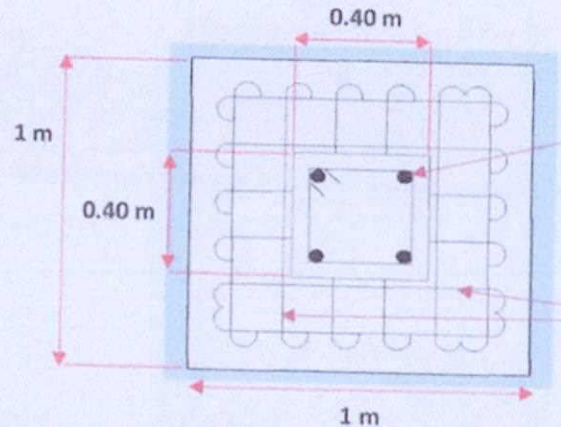

4-12mm \varnothing Main Bars w/ 10mm \varnothing Ties spaced
4@50mm,
4@100mm,
REST@150mm O.C.

6-12mm \varnothing Main Bed Bars Spaced
150mm O.C. B.W.

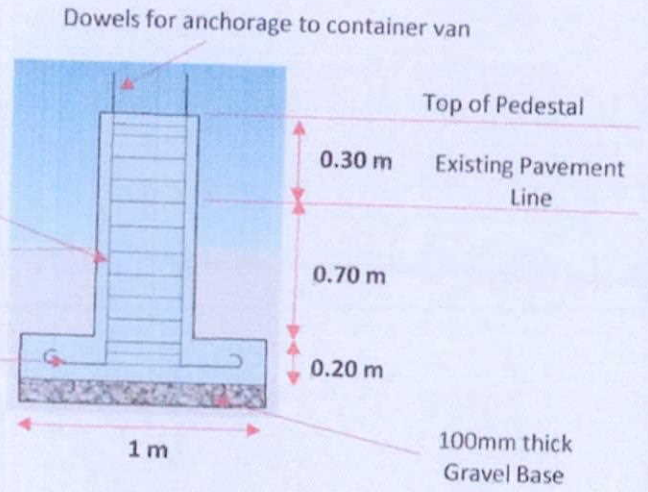

PEDESTAL DETAILS

Note: For Stairs, use 6" Load Bearing CHB with 12mm \varnothing bars as reinforcement, Run is at least 300mm, Rise is at least 200 mm, width of at least 1025mm.

<p>OFFICE OF THE OMBUDSMAN Area Office for Mindanao</p>	<p>Supply, delivery, and installation of 2 units 40-footer or 4 units 20-footer pre fabricated Container Van as Storage Facility for the Office of the Ombudsman, Area Office for Mindanao Use</p>	<p>CONTENTS: Pedestal and Stairs Layout Pedestal Details</p>	<p>SHEET NO. S - 1</p>
--	--	---	-----------------------------------

ANNEX "H-5"

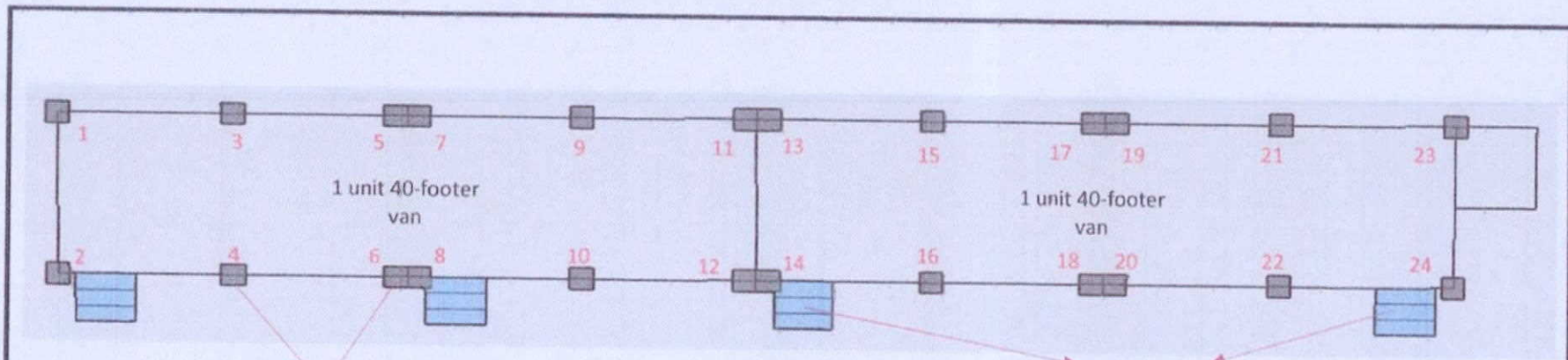

Concrete Pedestals

PEDESTAL AND STAIRS LAYOUT

CHB Stairs

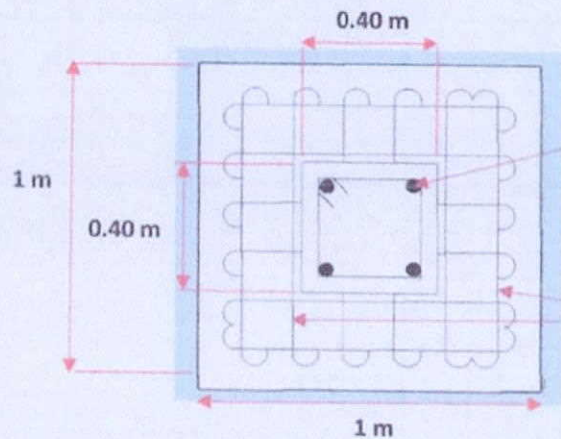

PEDESTAL DETAILS

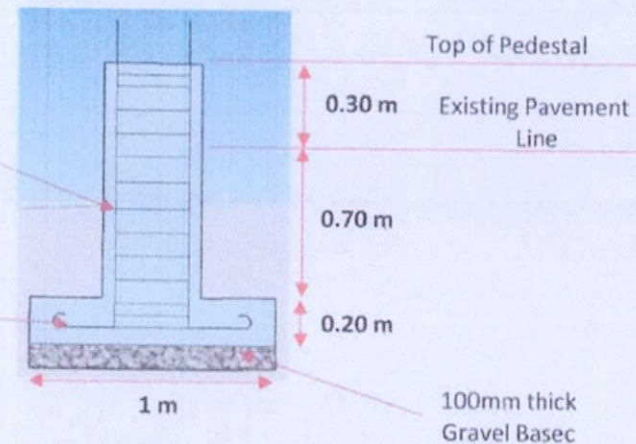

Note: For Stairs, use 6" Load Bearing CHB with 12mm \varnothing bars as reinforcement, Run is at least 300mm, Rise is at least 200 mm, width of at least 1025mm

<p>OFFICE OF THE OMBUDSMAN Area Office for Mindanao</p>	<p>Supply, delivery, and installation of 2 units 40-footer or 4 units 20-footer pre fabricated Container Van as Storage Facility for the Office of the Ombudsman, Area Office for Mindanao Use</p>	<p>CONTENTS: Pedestal and Stairs Layout Pedestal Details</p>	<p>SHEET NO. S - 1 (40)</p>
---	--	--	---------------------------------